

High Speed #8 Planer Kit

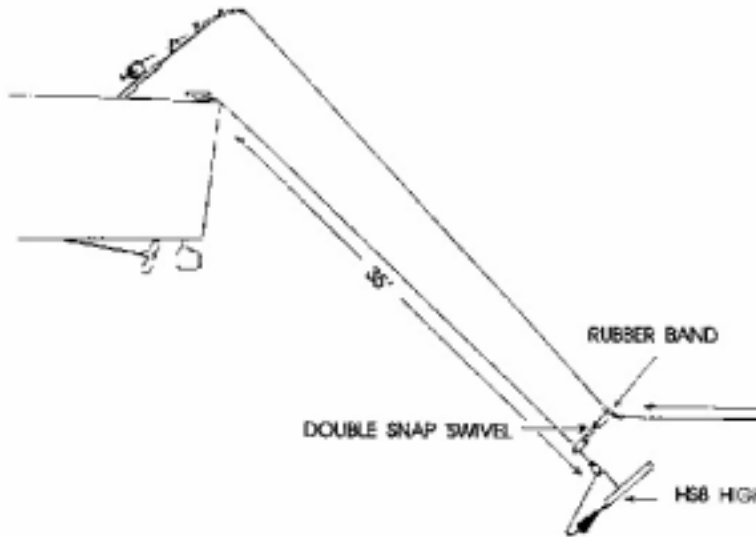

Instructions

Attach one end of the double snap swivel to the mono planer leader. Open the other snap and place the rubber band inside the snap (leaving the snap open). Make several loops around the line from your rod with the rubber band and place the end in the snap and close. As you let the lure out, the double snaps and band will go down to the planer. When a fish strikes, the rubber band will break and release from the planer allowing you to fight the fish freely. With a supply of double snap swivels and rubber bands, it is not necessary to retrieve the planer after each strike. Simply repeat the process described above, and collect the double snap swivels at the end of the day. If you wish to use a more elaborate system than the rubber band release, one of many release clips available will do an excellent job.

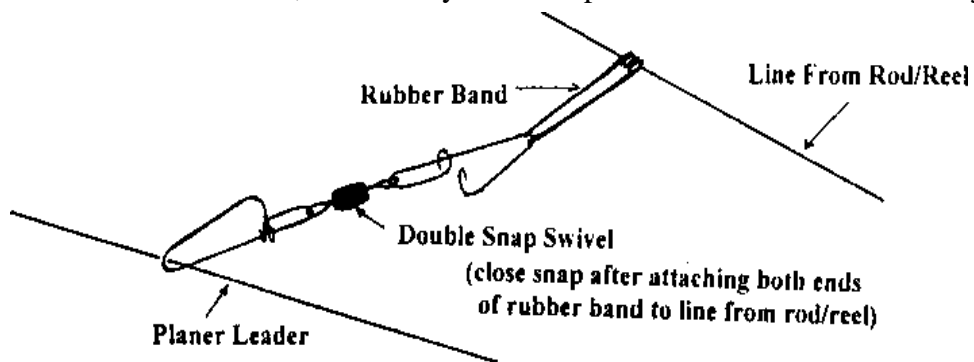

Setting and Retrieving Planers

To set the planer, attach the snap swivel from the planer line to the brass ring on the planer and ease it into the water at a 45-degree angle. Should the planer trip while fishing, it may be reset by pulling the planer line forward (2' to 3') and then releasing. This may take several attempts since you must change the altitude of the planer in order to get it from the neutral position into the planing position. A slightly slower boat speed will help. Your planer may be tripped for retrieval by pulling forward and releasing the planer line (as above).

Planer Depth

Planers will run at a 45-degree angle and achieve approximately one foot of depth for each two feet of planer line when used with appropriate line. There is a point where a planer reaches its optimum depth. For example, 50' of planer line will probably result in a planing depth of 25'. Unfortunately, it does not follow that 100' of line will generate 50' of depth. It is more likely that 125-150' of planer line would be required. Speed will only take a planer down so far and the process reverses itself. You can see this if you pull a planer at very high speed. Eventually, it will actually jump out of the water. Diameter and density of the planer line or cable is an important factor relative to depth. Monofilament lines run deeper than braided lines; and stainless steel cable (275 to 400 lb. test) will obtain even greater depths. For a detailed explanation of planers, how they work and the various factors affecting operation and depth, write Sea Striker, P.O. Box 459, Morehead City, NC 28557 or service@seastriker.com.